

THE CARRIER WAVE

PHANTOM FLYERS R/C CLUB



ama #393 SAINT CHARLES, MO

March 2018

Newsletter of the Phantom Flyers R/C Club

<http://phantomflyersrc.com>

CLUB OFFICERS

Contact Number

| | |
|-----------------------------------|----------------|
| President - Jan Jansen | (314) 921-9420 |
| Vice President - Don Grzina | (636) 233-0193 |
| Secretary - Jim West | (636) 387-0804 |
| Treasure - Jose' Espinosa | (636) 947-6067 |
| Safety Officer - Dave Evans | (636) 448-4800 |
| Field Manager - Don Grzina | (636) 233-0193 |
| Chief Flight Instructor - TBD | |
| Activities Chairperson - Ed White | (636) 441-6431 |

Send Membership Renewals to:

Jim West

9 Teak Court

St. Peters, MO 63376

Board of Directors:

Work

Home

| | | |
|-----------------|----------------|----------------|
| Ed White | (314) 232-1479 | (636) 441-6431 |
| Dan Sundman | (314) 749-4029 | (636) 352-0150 |
| Mitch Galatioto | (314) 234-5141 | |
| Dave Evans | Retired | (636) 448-4800 |

**Phantom Flyers Club Meeting Minutes
February 18, 2018**

President Jan Jansen opened the meeting at 7:00 pm at Mark Twain Hobby. There were 12 members in attendance.

Secretary's Report

The Club currently has 37 regular members. The Club AMA renewal was submitted.

Treasurer's Report

Club finances were reviewed by Jose.

GSLMA Report

There was no GLSMA report

Field Managers Report

- There was not much to report.

Activities Chair Report

- ED is starting the process of establishing a schedule. He is coordinating with Brian from Wight City Flyers.
- Vince Bartone has scheduled a Pattern primer on Mother's Day.
- The Fort Scott Pattern contest is no more due to extensive field damage.
- We will definitely have Vista Contest and the MSVA will also have a monthly 2m glider contest.
- Another scale fly in was discussed
- Four Float fly's should happen
- Discussed having an Open House to get new people interested.

Old Business

Mark Twain has been given the Club Roster. Club members will now get 10% off their purchases at Mark Twain.

New Business

- Runway repair party will be needed. Don is thinking of scheduling it at the end of March or the beginning of April.
- Increased dues were suggested for consideration to make up for smaller attendance.
- It was suggested to contact less active members to get some feedback.

jjw 3/17/18

Wright Flyer proposed schedule as presented by Brian during the February meeting

2018 Phantom-Wright Schedule.xls

| Month | Week End Dates | Event Date | Day of Week | Phantom Flying Event - 2017 | Week End Dates | Event Date | Day of Week | Phantom Flying Event - 2018 Proposed | Week End Dates | Event Date | Day of Week | Wright Flying Event - 2018 Proposed |
|-----------|----------------|------------|-------------|--|----------------|------------|-------------|--|----------------|------------|-------------|--|
| January | 31-01 | | | | 06-07 | | | | 06-07 | | | |
| | 07-08 | | | | 13-14 | | | | 13-14 | | | |
| | 14-15 | | | | 20-21 | | | | 20-21 | | | |
| | 21-22 | | | | 27-28 | | | | 27-28 | | | |
| February | 04-05 | | | | 03-04 | | | | 03-04 | | | |
| | 11-12 | | | | 10-11 | | | | 10-11 | | | |
| | 18-19 | | | | 17-18 | | | | 17-18 | | | |
| | 25-26 | | | | 24-25 | | | | 24-25 | | | |
| March | 04-05 | | | | 03-04 | | | | 03-04 | | | |
| | 11-12 | | | | 10-11 | | | | 10-11 | | | |
| | 18-19 | | | | 17-18 | | | | 17-18 | | | |
| | 25-26 | | | | 24-25 | | | | 24-25 | | | |
| April | 01-02 | | | | 31-01 | 01 | Sun | Easter | 31-01 | 01 | Sun | Easter |
| | 08-09 | | | | 07-08 | | | | 07-08 | | | |
| | 15-16 | 16 | Sun | Easter | 14-15 | | | | 14-15 | | | |
| | 22-23 | | | | 21-22 | | | | 21-22 | 21 | Sat | Clement Memorial Fly-In (Show 'n Tell) |
| | 29-30 | | | | 28-29 | | | | 28-29 | 28 | Sat | Clement Memorial Fly-In (rain date) |
| May | 06-07 | 13 | Sat | Vista/Electric Sailplane Contest | 05-06 | 05 | Sat | Vista/Electric Sailplane Contest | 05-06 | | | |
| | 13-14 | 14 | Sun | Mother's Day | 12-13 | 14 | Sun | Mother's Day | 12-13 | 13 | Sun | Mother's Day |
| | 20-21 | 20 | Sat | KC Pattern Primer | 19-20 | 19 | Sat | KC Pattern Primer | 19-20 | | | |
| | 27-28 | 27 | Sat | FF - Innsbrook Memorial W/E - 9:00 - Noon | 26-27 | 26 | Sat | FF - Innsbrook Memorial W/E - 9:00 - Noon | 26-27 | 26 | Sat | FF - Innsbrook Memorial W/E - 9:00 - Noon |
| June | 03-04 | | | | 02-03 | | | | 02-03 | | | |
| | 10-11 | | | | 09-10 | | | | 09-10 | 09 | Sat | Fun Fly & Pot Luck Lunch |
| | 17-18 | 18 | Sun | Father's Day | 16-17 | 17 | Sun | Father's Day | 16-17 | 17 | Sun | Father's Day |
| | 24-25 | 24 | Sat | E-Fly | 23-24 | 23 | Sat | E-Fly | 23-24 | 23 | Sat | FF - Elfrink Lake |
| July | 01-02 | 01 | Sat | Vista/Electric Sailplane Contest | 30-01 | 30 | Sat | Vista/Electric Sailplane Contest | 30-01 | | | |
| | 08-09 | | | Sports/Intermed Pattern Contest (Open) | 07-08 | 07 | Sat | Sports/Intermed Pattern Contest (Open) | 07-08 | 07 | Sat | Fun Fly & Pot Luck Lunch |
| | 15-16 | | | | 14-15 | | | | 14-15 | | | |
| | 22-23 | 22 | Sat | Meet Me in St Louis Pattern Pre-Nats | 21-22 | 21 | Sat | Meet Me in St Louis Pattern Pre-Nats | 21-22 | 21 | Sat | FF - Elfrink Lake - 10:00 AM |
| | 29-30 | 25-29 | T - S | Pattern Nats - Arkansas | 28-29 | 24-28 | T - S | Pattern Nats - Arkansas | 28-29 | | | |
| August | 05-06 | 06 | Sat | Joint Fun Fly at Phantom Field | 04-05 | 04 | Sat | Joint Fun Fly at Phantom Field | 04-05 | 04 | Sat | Joint Fun Fly at Phantom Field |
| | 12-13 | 12 | Sat | Vista/Electric Sailplane Contest | 11-12 | 11 | Sat | Vista/Electric Sailplane Contest | 11-12 | | | |
| | 19-20 | | | | 18-19 | 18 | Sat | | 18-19 | 18 | Sat | Fun Fly & Pot Luck Lunch |
| | 26-27 | 26-27 | | Phantom Hosted Pattern Contest | 25-26 | 25-26 | | Phantom Hosted Pattern Contest | 25-26 | | | |
| September | 02-03 | 02 | Sat | FF - Innsbrook Labor Day W/E - 9:00 - Noon | 01-02 | 01 | Sat | FF - Innsbrook Labor Day W/E - 9:00 - Noon | 01-02 | 01 | Sat | FF - Innsbrook Labor Day W/E - 9:00 - Noon |
| | 09-10 | 10 | Sat | Joint Fun Fly at Wright Field | 08-09 | 08 | Sat | Joint Fun Fly at Wright Field | 08-09 | 08 | Sat | Joint Fun Fly at Wright Field |
| | 16-17 | 16 | Sat | Vista/Electric Sailplane Contest | 15-16 | 15 | Sat | Vista/Electric Sailplane Contest | 15-16 | | | |
| | 23-24 | 23-24 | Sat-Sun | Fort Scott Pattern Contest | 22-23 | 22-23 | Sat-Sun | Fort Scott Pattern Contest | 22-23 | | | |
| | 30 | | | | 29-30 | | | | 29-30 | 20 | Sat | Fly-In & Pot Luck Lunch |
| October | 01 | | | | 06-07 | | | | 06-07 | | | |
| | 07-08 | | | | 13-14 | | | | 13-14 | 13 | Sat | Chili Cook-Off |
| | 14-15 | | | | 20-21 | | | | 20-21 | | | |
| | 21-22 | | | | 27-28 | | | | 27-28 | | | |
| November | 04-05 | | | | 03-04 | | | | 03-04 | | | |
| | 11-12 | | | | 10-11 | | | | 10-11 | | | |
| | 18-19 | | | | 17-18 | | | | 17-18 | | | |
| | 25-26 | | | | 24-25 | | | | 24-25 | | | |
| December | 02-03 | | | | 01-02 | | | | 01-02 | | | |
| | 09-10 | | | | 08-09 | | | | 08-09 | | | |
| | 16-17 | | | | 15-16 | | | | 15-16 | | | |
| | 23-24 | | | | 22-23 | | | | 22-23 | | | |
| | 30-31 | | | | 29-30 | | | | 29-30 | | | |

- Holiday Impacts
- Float Fly Date
- Flying Event at Wright Field
- Phantom Events

GSLMA Meeting Minutes (submitted by Harold Weaver)

I'm back from Snowbird time and I did attend the GSLMA meeting this week. See attached minutes for last month's meeting. GSLMA is still meeting at the Oak Bend Library near the intersection of Big Bend and Rt 44 until they are able to get back to the Grand Glaze library near Rt 141 and Big Bend which has been under renovation. I think the new GSLMA president, Fred Cronenwett who is experienced in RC Scale judging, although a little laid back, is going to be good for GSLMA. If you go to the GSLMA.com website on the Home page you will now see a very good dissertation explaining

GSLMA and why it is necessary to collect \$30 for each Buder Park permit to fly and to keep a large treasury balance to deal with the many costly repairs needed for maintenance materials and repairs to keep the RC, Control Line, and Drone racing area in good flying shape. Additional fencing is to be added around the Drone racing area to keep people from wondering through the area while racing and racing practice is in progress. Cleanup of from the recent Buder Park flooding was accomplished by volunteers using a water truck and power washer in the Control Line area. It is felt that the little amount of mud on the RC runways will be washed away by rain showers.

GSLMA Meeting – Thursday, February 6th, 2018

Location: Kirkwood Oak Library Branch

Notes by: Jeffrey C. Young

Meeting called to order: 7:05pm

Roll Call.

January minutes read. Motion, second, and passed. Typographical

Treasures Report:

BB: \$19,988.17

Total Deposits: \$711.00

Debit Chk #893 Wind sock: \$89.27

Debit Walgreens: \$29.40

Returned Check: \$40.00

Debit Bank Paper Fee: \$5.00

Total Debits: \$163.67

EB: \$20,535.50

Motion, second, and passed.

Buder Park Permits:

Permits 2018 1/01/2018 to 1/31/2018: 37

Permits 2016 Total: 233

Permits 2017 Total: 245

Permits 2018: 121

Old Business:

- Fred contacted AMA for field improvement grant on paving, sealing. We can apply, but all expenses must be March 1st or after.
- Gary P. to see if SLCPD can install. We will check the status and install otherwise.
- Buder Fly August 12th (will fall on Model Aviation Day)– Fred will get paper work completed for event.
- Non-permit flyers. Out of (5) people checked only (1) had permit.
- April 21st Aero Pilots Piper Cub Day.
- Spirit of St. Louis Full Size Air Show – will see if we can get a 50x50 grassy area for display. October 13 and 14. Need to have a firm commitment for flyers. Ask clubs if they would be willing to help. Mention Stem and drone education.
- June 23rd Drone Day with Aero Pilots at Buder.

New Business:

- Control Line Area – make a larger center pad for CL circle. Motion for \$500.00 replacement concrete carrier control line circle pilot area. Second, pass, none opposed.
- Donation from a flyer getting out of the hobby to Gary H. at Buder one day unannounced. Give away items at upcoming GSLMA meeting for all current Buder permit holders.
- Craig Anderson needs the master email list to promote GSLMA Face Book page.
- Park Pilot magazine will be doing an article on Ed and Beth Paszkiewitez.
- February 25th Control Line Event. May have an article speed contest from 2017.

Meeting closed 8:16pm

MVSA Club

Many of us enjoy playing Hunters of Thermals (soaring) and to join the MVSA (Mississippi Valley Soaring Association) for their 2M and HL activities. Due to weather it has been postponed but watch your inbox for updates.

Hi Fliers,

This is just a reminder that we have our 1st 2M/HL contest this Saturday. (weather permitting)
As of now the rain should be done Friday with only scattered showers on Saturday. If that changes I will put out a note Friday evening or Saturday morning.

Since the club voted to hold the two classes separately rather than alternating rounds, we will hold the HL portion from 9-12 and the 2M portion from 12-3.

It is greatly requested that as many folks as possible from both groups, come out for both parts, so that we have enough people for timers that we can run flight groups in both events. Timing for yourself and only flying AULD in HL is no fun compared to flying real tasks, and with 2M being run MOM we will need as many timers as possible.

HL – Hoping to have as many fliers out as possible. Good News! Jeff Brundt just bought my Polaris and will be able to fly. Duane Youngman also bought my (Robert's old) Stobel and he should be in the air shortly. Everyone who has them, bring all your Palm Pilots for timing. I'll bring my two.

2M – We will be flying Man-On-Man, 6 minute max, 25' landing tape using high starts for launching.

Any 2meter allowed, any controls allowed, electric 2meters allowed.

For this to work well, each pilot needs to have their own high start (max 100' rubber, max 350' line, max stretch 200')

If we have enough high starts, we might be able to share high starts, but the owner has 1st dibbs so if you don't bring one, you'll have to take pot luck.

Electric 2meters will be allowed with CAM set to 100M.

See you all Saturday,
Wayne

Larry, will you please pass this on to the Phantoms fliers? Please encourage them to come out to help with HL too. Thanks.

Members Models/Projects

Your Editor purchased an old Yellow Aircraft 1/10" scale F/A-18 glow ducted fan model late in the flying season. The plan was to get it converted to EDF (Electric Ducted Fan) for the 2018 season. The model looked great in the pictures and he included the Dynamax glow ducted fan unit without that fossil burning thing attached. It was delivered via Greyhound and was placed in quarantine (in the garage) for a month in an effort to lose heavy smoker smell. I was good with it but the Commander in Chief was not having it...so I followed her orders! This is one of the pictures in the ad.



My first step was to assemble it and see how much work would be required. The clear canopy was gold/orange faded, the landing gear was wobbly and would not tighten. The nose gear strut, after a few compressions finally broke. The servos were all analog types and those don't seem to play well with my Airtronics SD-10GS FHSS-3 setup so all but the steering servo will be replaced.

I have converted the Dynamax fan unit to electric and need to solder some leads on it to do a test run. This is a 12S 4500-5000 watt setup...I hope.

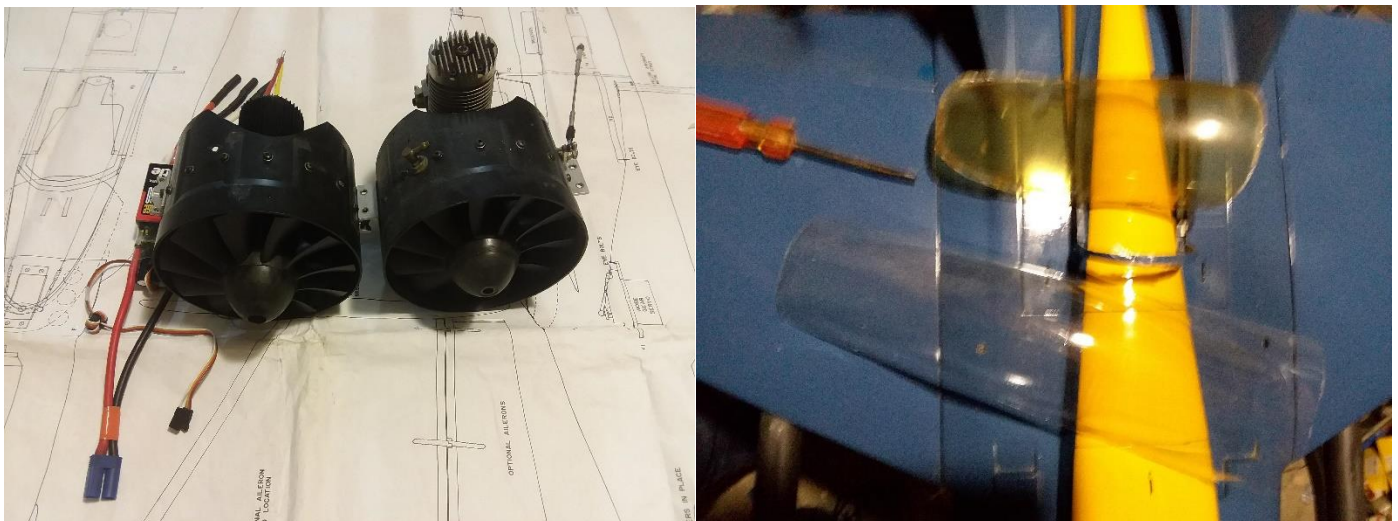

I have used my 3D printer to fab a few parts that I drew in Fusion 360. You can't have a Legacy Hornet without LEX fences and my replacement nose gear Robart strut looks too plain, but so did the original.

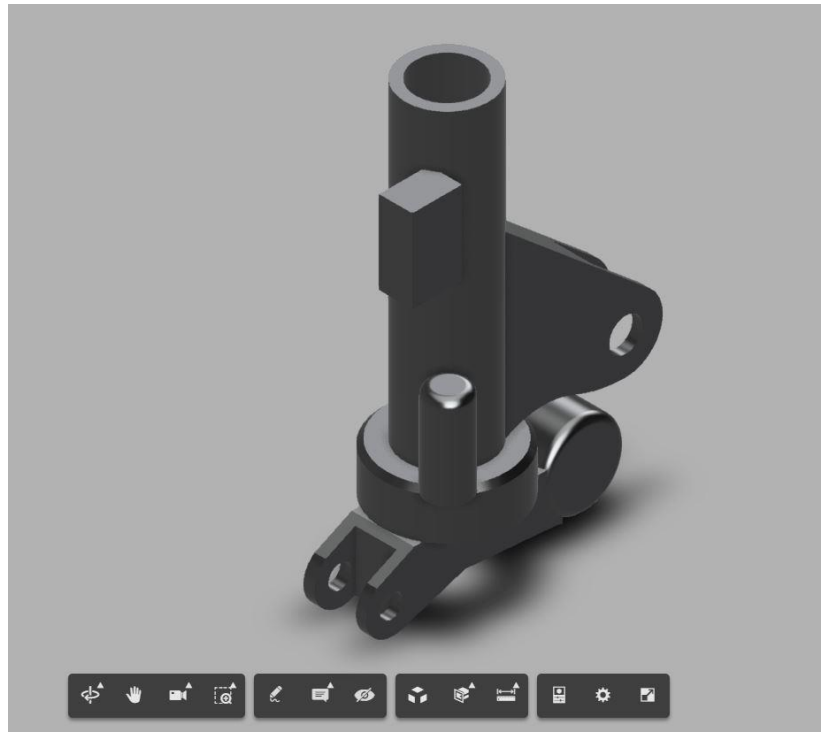
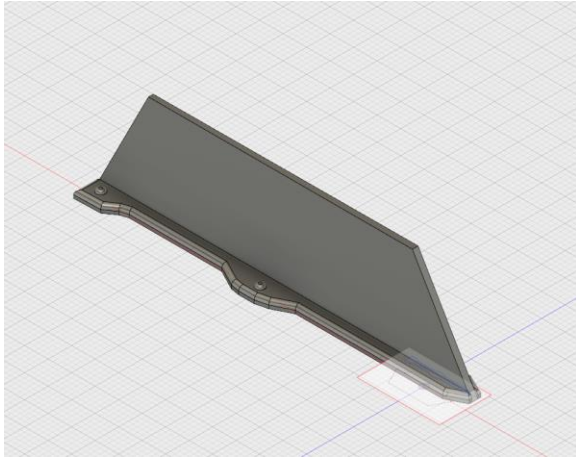

Hopefully I can get some pictures of what you guys have been working or its almost warm enough to actually see some of you guys at the field again!

Phantom Flyers RC CLUB

(Be sure to explore our website: phantomflyersrc.com)

2018 MEMBERSHIP APPLICATION

- Regular \$135/year x ____ yr(s) = _____
 Family (IRS Dependents) \$140/year x ____ yr(s) = _____
 Non-Participant (Non flying) \$15/year x ____ yr(s) = _____
****** Late Renewal Fee **** \$15** _____

}

Select
All
That
Apply

Note: All new applications received after 1 July of this year will receive next year's dues free

(Late fee required if member has not paid by 31 Dec)

Total Amount Due = _____

Make checks payable to:
Phantom Flyers RC Club, Inc.

| | <u>Eligible Member</u> | <u>Additional Family Member</u> |
|--------------------------------|------------------------|---------------------------------|
| Member Name (/Nickname) | _____ | _____ |
| AMA Number | _____ | _____ |
| Primary Phone (home/cell) | _____ | _____ |
| Secondary Phone (work/cell) | _____ | _____ |
| Street | _____ | _____ |
| City, State, Zip | _____ | _____ |
| Spouse's Name | _____ | _____ |
| Primary E-Mail Address | _____ | _____ |
| Can Mow Flying Field? (Yes/No) | _____ | _____ |

My signature below signifies that:

I have read, understood and will abide by the Phantom Flyers RC Safety and Field Use Rules.

I understand that my participation in this activity is purely voluntary and I agree to hold Phantom Flyers RC Club, Inc. harmless for any and all liability for any injuries including death, which I might sustain while participating in this activity.

Signature: _____ **Date:** _____

Submit form and membership dues to:

Jim West
 9 Teak Court
 Saint Peters, MO 63376
 Full members only, please send S.A.S.E.

| | | |
|---|---------------------------------------|--|
| <i>For Club Administrative Use Only</i> | Dues Received _____ Date | Current AMA Received/Shown _____ Date |
|---|---------------------------------------|--|

<http://phantomflyersrc.com/>

<https://www.facebook.com/Phantom-Flyers-RC-Club-139791882811519/>

Check there for the back issues of the Carrier Wave Newsletter, mowing schedule, event calendar and club roster/contact information (handy for mowing).

Articles, pictures and tech notes for publishing in the Carrier Wave are always appreciated. Let us know what you are building, repairing or flying!

Send them to:

kevcox@charter.net